

## Module 4: Sensitivity Analysis and CEA Thresholds

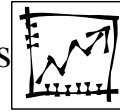

1. Deterministic Sensitivity Analysis



2. Thresholds and CEA



3. CEA Threshold Example

108  
2/28/2008

## Deterministic Sensitivity Analysis

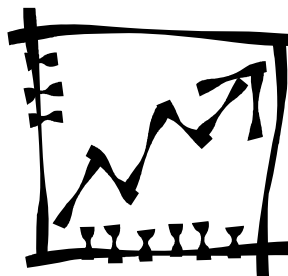
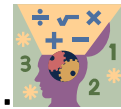

109  
2/28/2008



## Deterministic Sensitivity Analysis

- Sensitivity Analysis studies how a model's outputs are affected by variation in inputs
- Two types of Sensitivity Analysis are supported by TreeAge Pro
  - Deterministic Sensitivity Analysis
    - How parameter **VARIABLES** affect model outputs
    - Covered here
  - Probabilistic Sensitivity Analysis
    - How parameter **DISTRIBUTIONS** affect model outputs
    - Covered in later section
- Both are recalculation “loops”, with uncertain parameters changing between recalculations

110  
2/28/2008



## Deterministic Sensitivity Analysis

- Calculation method:
  - Simple
    - Single-attribute → one graph/one function
  - Multi-Attribute (e.g., CEA)
    - C/E → many graphs, functions (e.g., incrementals, CE plane, ...)

111  
2/28/2008

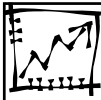

# Deterministic Sensitivity Analysis



- Open tree Example2-Variables.tre (save as Example4-?????.tre)

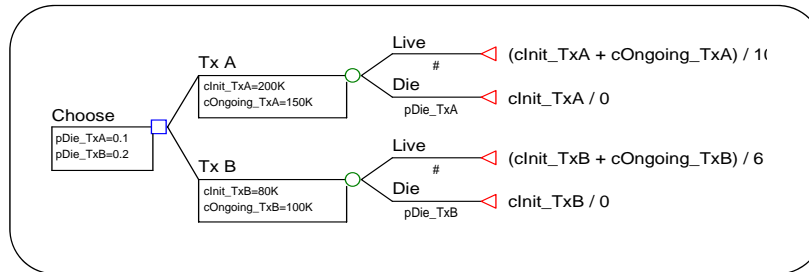

- Select root node
- Change Calc Method to Simple and Use payoff 2 (temporarily)
- Menu: Analysis > Sensitivity Analysis > One-Way...

112  
2/28/2008



# Deterministic Sensitivity Analysis



- Sensitivity Analysis window will open

- Pick variable
- Set value range
- Set interval count

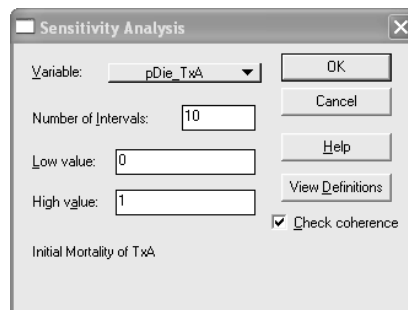

- To get nice intervals:  
**HIGH – LOW** and divide evenly

113  
2/28/2008

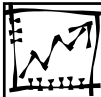

# Deterministic Sensitivity Analysis



- Output from “Simple” analysis (one active payoff)
  - Generates a simple line graph
  - X-axis: Change in variable value
  - Y-axis: Change in effectiveness

- Effectiveness of Tx A decreases as pDie\_TxA increases
- Effectiveness of Tx B is unaffected by changes in pDie\_TxA
- Visual threshold where Tx A becomes less effective than Tx B

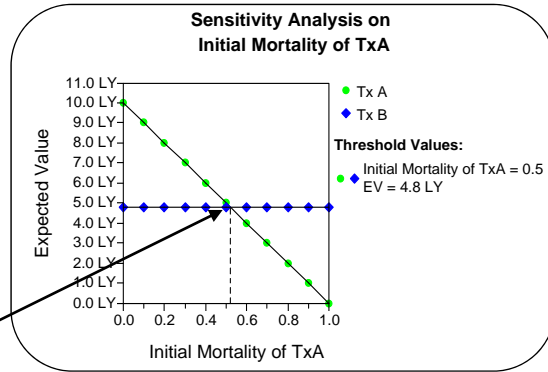

114  
2/28/2008



# Deterministic Sensitivity Analysis



- Text Report shows repeated analysis for each interval

Initial Mortality of ...	TxA	TxB
0	10.0 LY	4.8 LY
0.1	9.0 LY	4.8 LY
0.2	8.0 LY	4.8 LY
0.3	7.0 LY	4.8 LY
0.4	6.0 LY	4.8 LY
0.5	5.0 LY	4.8 LY
0.6	4.0 LY	4.8 LY
0.7	3.0 LY	4.8 LY
0.8	2.0 LY	4.8 LY
0.9	1.0 LY	4.8 LY
1	0.0 LY	4.8 LY

Each new value of pDie\_TxA generates a new effectiveness measure for the strategy

115  
2/28/2008



# Deterministic Sensitivity Analysis



- Line Graph:

- Options

- Axes range
- Numeric format

- Resize, zoom document
- Print, preview, export picture
- Layout, fonts, colors
- Export as **Excel chart**

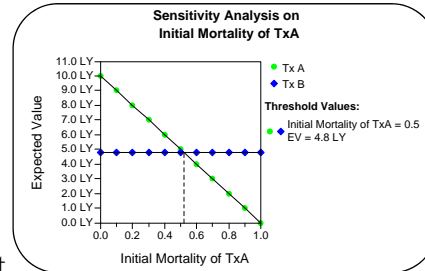

116  
2/28/2008

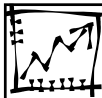

# Deterministic Sensitivity Analysis



- Example 4: Change calc method back to Cost/Effectiveness and rerun analysis

- Cost/Effectiveness Sensitivity Analysis window opens

- Gives access to **many** graphs/reports
- We will study these in next section:

### Thresholds and CEA

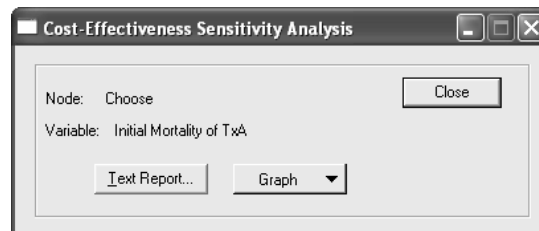

117  
2/28/2008

# Thresholds and CEA



118  
2/28/2008



# Thresholds and CEA



- A threshold is a point where there is a change in decision recommendation within the range of uncertainty
  - Comparing strategies; or
  - Strategy compared to budget or other ceiling
- Sometimes represented in graphs as crossing points
  - The threshold was fairly easy to see in the “simple” model when Tx A became less effective than Tx B

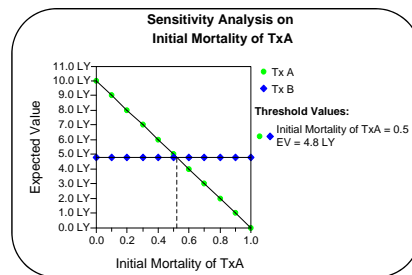

119  
2/28/2008



## Thresholds and CEA

- Cost-Effectiveness thresholds are more complex
  - Need to consider cost, effectiveness and WTP
  - Change in **relative** cost-effectiveness
    - Change in dominance and/or efficiency
    - Changes in cost and/or effect ordering
    - Also consider different WTP (ceiling ICER)
- How to identify visually?
  - ICER graph and challenges (next slides)
  - Net Benefits graph – clearest

120  
2/28/2008



## Thresholds and CEA

- Sensitivity Analysis for a Cost/Effectiveness cannot be represented as a single line graph
- The Cost/Effectiveness Sensitivity Analysis window provides access to several graphs/reports
- We will look at a couple of these graphs

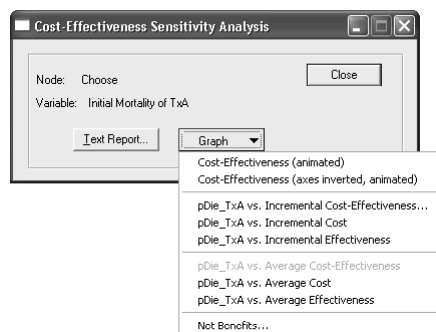

121  
2/28/2008



## Thresholds and CEA



- Graph variable vs. ICER
  - Shows the change in ICER as  $pDie\_TxA$  changes
  - The least costly option (“baseline”) is graphed at  $ICER = 0$

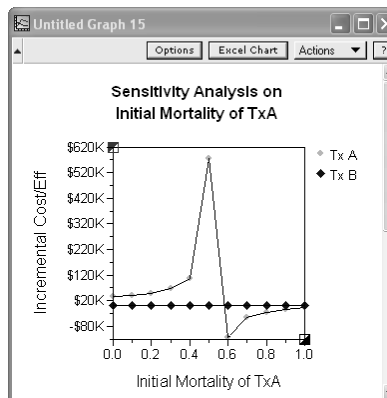

122  
2/28/2008



## Thresholds and CEA



- Graph variable vs. ICER
  - The spike occurs when IE becomes very small
    - $ICER = IC/IE$
    - When IE is very small, ICER becomes very large (positive or negative)

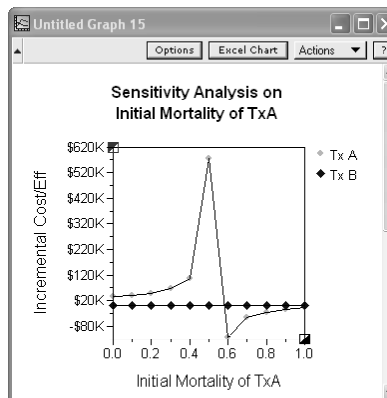

123  
2/28/2008



# Thresholds and CEA



## ● Graph variable vs. ICER

- Negative ICER values occur when  $IE < 0$ 
  - Strategy TxA becomes absolutely dominated ( $IC > 0, IE < 0$ )
- The spike occurs when IE becomes very small
  - $ICER = IC/IE$
  - When IE is very small, ICER becomes very large (positive or negative)

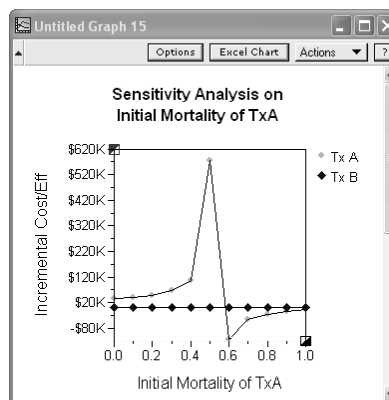

124  
2/28/2008



# Thresholds and CEA



## ● Variable vs. ICER

- We also need to look at an ICER threshold...
  - When does the ICER for TxA exceed our WTP?
- Set horizontal line at \$50K to represent our WTP (**Options** button)
- See threshold graphically...
  - ICER exceeds \$50K where the ICER curve meets our horizontal line
- Crossing point reported in **Text Report** "Notes" section
- Does not always work well:
  - More than two strategies problematic
  - Asymptotes (very small IE) cause false thresholds
- **Net Benefits** graph interpretation is quicker, easier

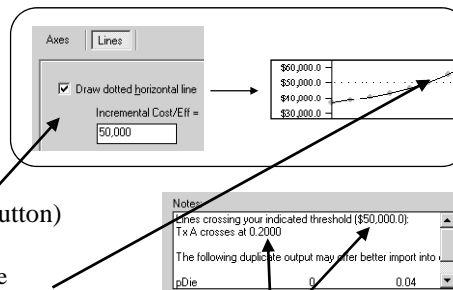

125  
2/28/2008



# Thresholds and CEA



- Net Benefits sensitivity/thresholds
  - Net Benefits calculations build the threshold ICER (WTP) into calculations, as the **weight on effectiveness**, or monetary value per unit of additional effect:

$$\text{NMB} = \frac{(E * \text{WTP}) - C}{(\text{LY} * \$/\text{LY}) - \$} = \$ \quad \text{monetary scale}$$

$$\text{NHB} = \frac{E - (C / \text{WTP})}{\text{LY} - (\$/ (\$/\text{LY}))} = \text{LY} \quad \text{effectiveness unit scale}$$

- By combining cost, effectiveness, and WTP into a single measure, graphs and thresholds become much clearer
  - Just maximize the Net Benefits measurement rather than balance cost & effectiveness relative to WTP
  - Same threshold search as ICER, but easier to identify

126  
2/28/2008



# Thresholds and CEA



- Net Benefits Graph

- Enter WTP
- Select strategies

- Line graph displays visual CEA thresholds for given WTP

- Same changes in optimal strategy identified in ICER graph/report

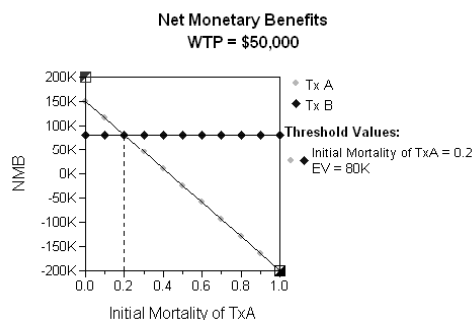

127  
2/28/2008



## Thresholds and CEA



- Net Benefits Graph
  - Works for any number of strategies
  - Strategy with the highest average Net Benefit is most cost-effective (i.e., optimal point on the cost-effective frontier for a given WTP)

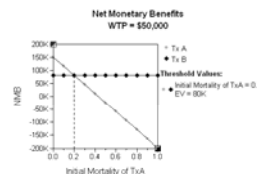

128  
2/28/2008



## Thresholds and CEA



- Sensitivity Analysis on WTP
  - Vary weight on effect (WTP) from 0 (i.e., ignore effect) to very high (ignore cost)
    - Changing WTP but not variable values
  - Analysis > Net Benefits
  - Strategies are equal when WTP ~ \$42K

Sensitivity Analysis on Willingness-to-pay

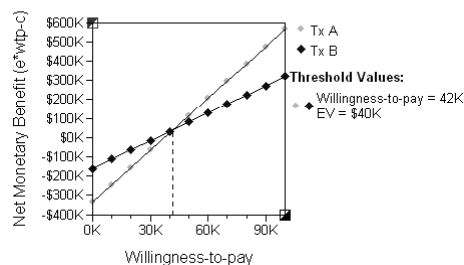

129  
2/28/2008



## Thresholds and CEA



- In CEA, we normally maximize effectiveness
  - What about **inverted** “effectiveness”? (i.e., minimize adverse events)?
  - Change tree preferences
    - C/E Decision Rules/Parameters
    - Invert incrementals

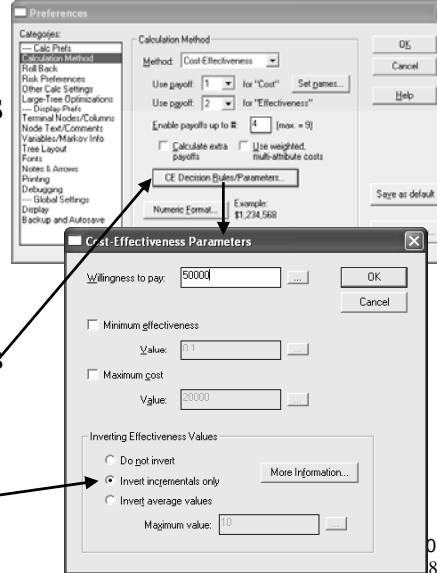

## CEA Threshold Example



- Example 4: Decision tree for new treatment
  - Two strategies for treatment of specific cancer
  - Compare cost/effectiveness of each strategy relative to WTP (**\$50K/LY**)
  - Each strategy has immediate cost and chance of mortality
  - Each strategy has a life expectancy and annual cost associated with chronic disease

## CEA Threshold Example



- Example 4: Decision tree for new treatment
  - Treatment A (new cancer drug)
    - Short-term probability of death: 25% (LE: ~0 yrs)
    - Surviving patients in two **risk subgroups**:
      - Subgroup X (80%): avg. life expectancy 9 yrs
      - Subgroup Y (20%): avg. life expectancy 4.5 yrs
    - Costs:
      - Initial treatment cost of \$55K (for everyone)
      - Follow-up/maintenance costs: \$1K / year
  - Treatment B (surgery/current standard of care)
    - Short-term probability of death : 10%
    - Surviving patients avg. life expectancy: 5.5 yrs (for everyone)
    - Costs:
      - Initial: \$10K (for everyone)
      - Follow-up costs: \$500 / year

132  
2/28/2008

## CEA Threshold Example



- Example 4: Decision tree for new treatment
  - Do baseline C/E analysis (for decision maker):
    - Calculate ICER...
      - Tx A “comparator” vs. Tx B “baseline”
  - Do sensitivity analyses (for analysts):
    - On parameter uncertainties in new therapy arm
      - Treatment A’s uncertain parameters
        - Tx A **short-term probability of death** (range: **0.1** to **0.4**)
        - Tx A **initial cost** (range: **\$30k** to **\$80k**)
      - ICER Threshold
        - WTP = **\$50K/QALY**
  - Optional: additional variables (e.g., for transparency, efficiency)

133  
2/28/2008

# CEA Threshold Example



## • Questions:

– What is the ICER for treatment A?

– Sensitivity analyses:

• Vary *short-term probability of death for Tx A* over its uncertainty. What is maximum rate such that Tx A is cost-effective, assuming WTP = \$50K/LY?

• What is maximum *initial cost for Tx A* such that Tx A is cost-effective? (Maintenance costs remain fixed.)

134  
2/28/2008

# CEA Threshold Example



## • Multiple solutions... including:

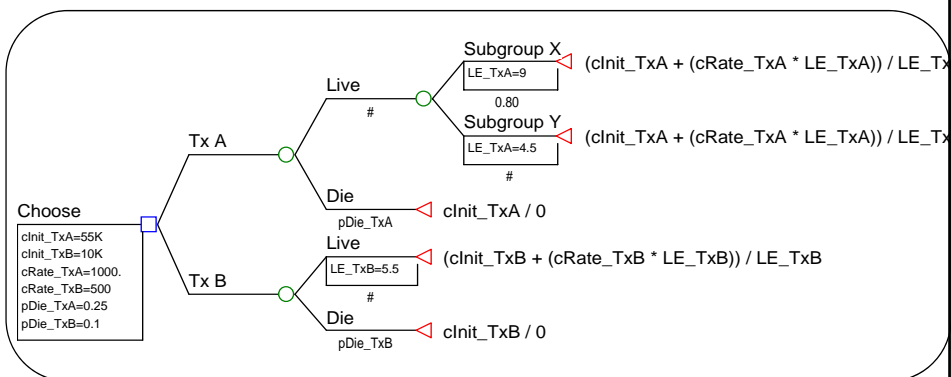

135  
2/28/2008

# Sensitivity Analysis and CEA Thresholds



- Questions?

- Deterministic Sensitivity Analysis



- Thresholds and CEA



- CEA Threshold Example